

Cubic mounts for TO5 and TO66 headers

data sheet describing the new TO5 and TO66 mount for enhanced temperature control

technology

The nanoplus TO5 and TO66 mounts are standardized plug and play systems for easy connection with electronics and optical set up while enhancing the temperature control of the laser.

key features

- ✓ improved heat distribution
- ✓ connectors for laser diode driver and temperature controller
- ✓ M6 thread for optical posts
- ✓ easy use with standard cage systems



TO5 Cube		
pin-out		
D-Sub-M	D-SUB-F	laser pinout
1	1 int. connected to 5	1 LD +
2 NTC +	2 PD*	2 LD -
3 NTC -	3 LD -	3 TEC -
4 TEC +	4 PD*	4 TEC +
5 TEC -	5 int. connected to 1	5 NTC +
6	6 LD -	6 NTC -
7	7 LD -	7 PD*
8	8 LD +	8 PD *
9	9 LD +	

TO66 Cube		
pin-out		
D-Sub-M	D-SUB-F	laser pinout
1	1 int. connected to 5	1 TEC +
2 NTC +	2 PD*	2 NTC -
3 NTC -	3 LD -	3 NTC +
4 TEC +	4 PD*	4 PD*
5 TEC -	5 int. connected to 1	5 PD*
6	6 LD -	6
7	7 LD -	7 LD +
8	8 LD +	8 LD -
9	9 LD +	9 TEC -

*photodiode is optional

nanoplus cubic mount for TO5 headers

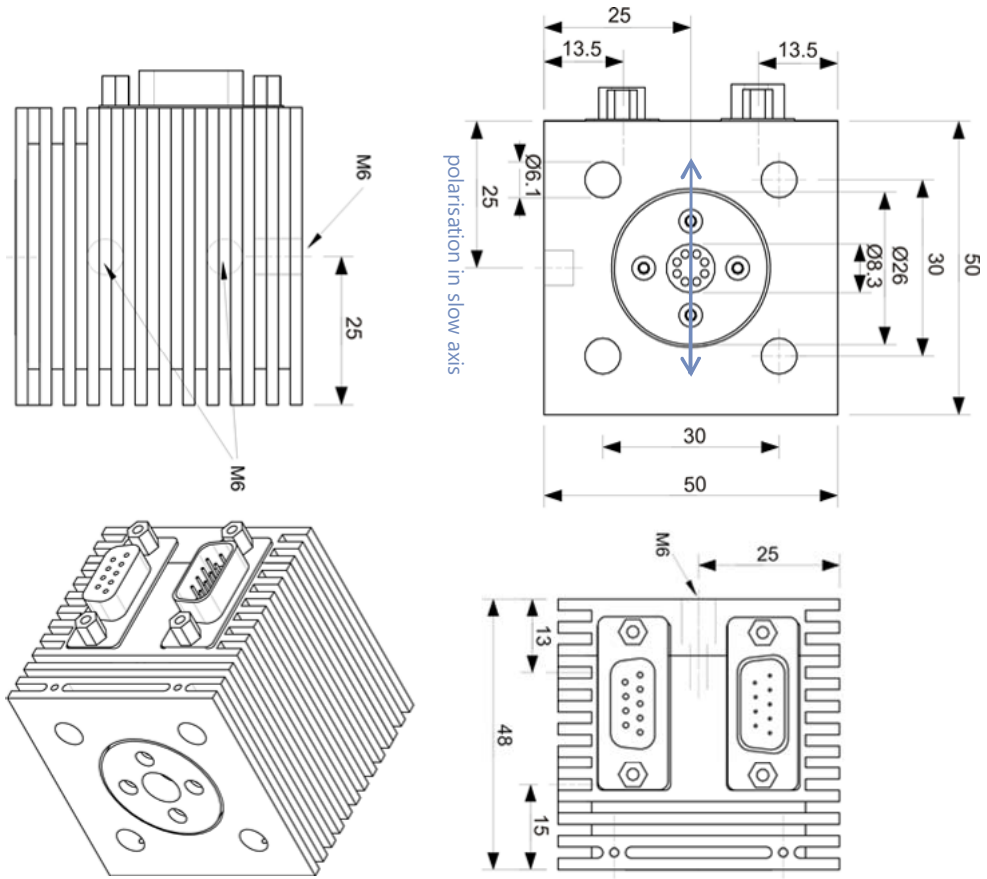

nanoplus cubic mount for TO66 headers

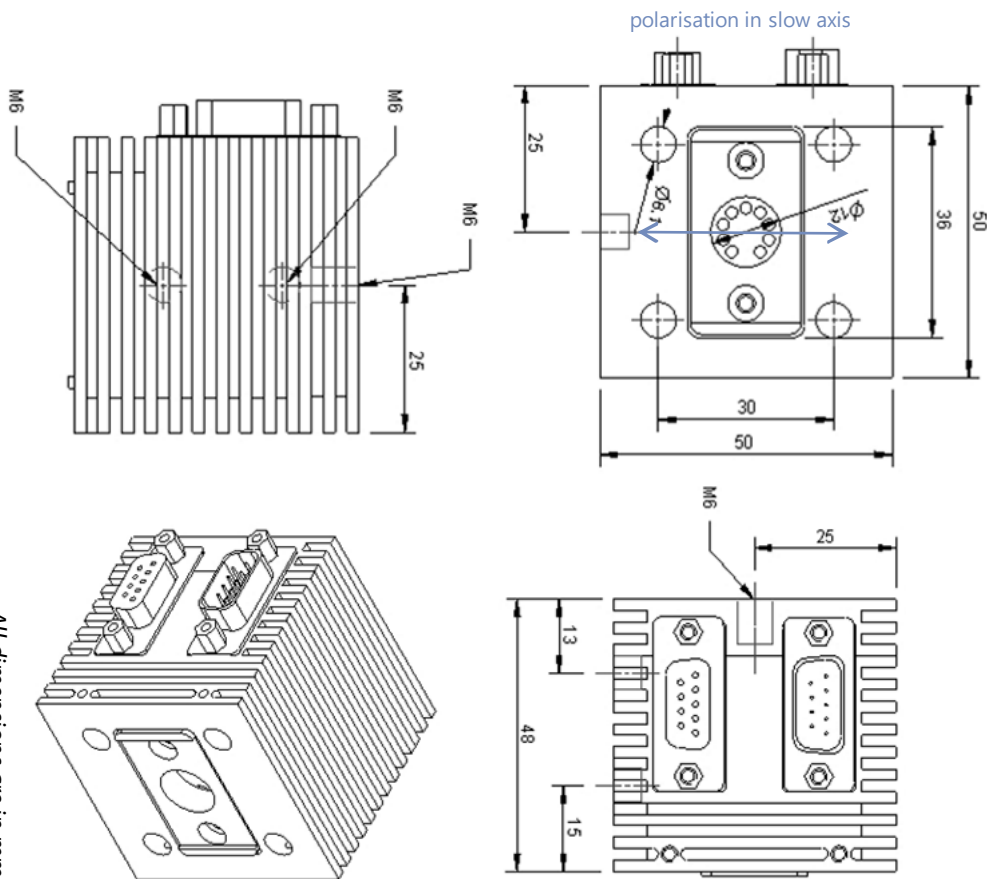

All dimensions are in mm.